

THIS DRAWING IS UNPUBLISHED. RELEASED FOR PUBLICATION, 19 .  
 © COPYRIGHT 19 BY AMP INCORPORATED. ALL RIGHTS RESERVED.

LOC	DIST	REVISIONS					
		P	LTR	DESCRIPTION	DATE	DWN	APVD
AF	50		H	REDRAWN PER 0G1A-0330-98	10/5/98	JR	JD

1 CONTINUOUS STRIP ON REELS AT A FEED OF  $27.68 \pm 0.13$  [ $.1.090 \pm .005$ ].

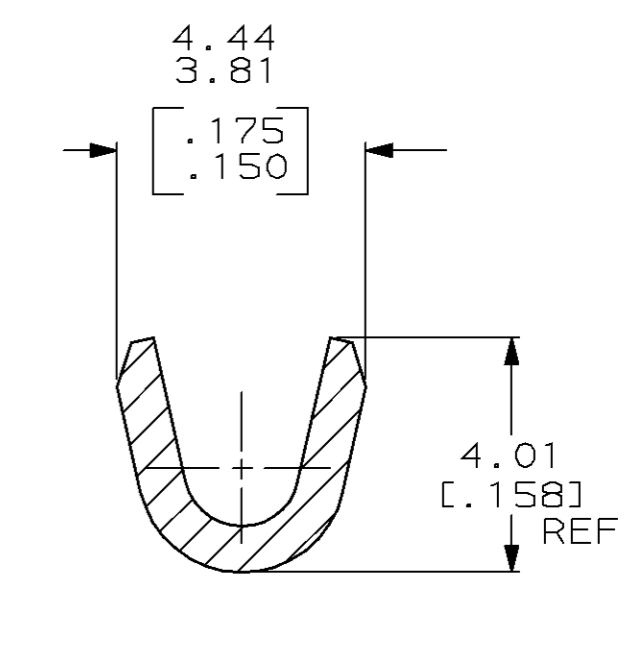
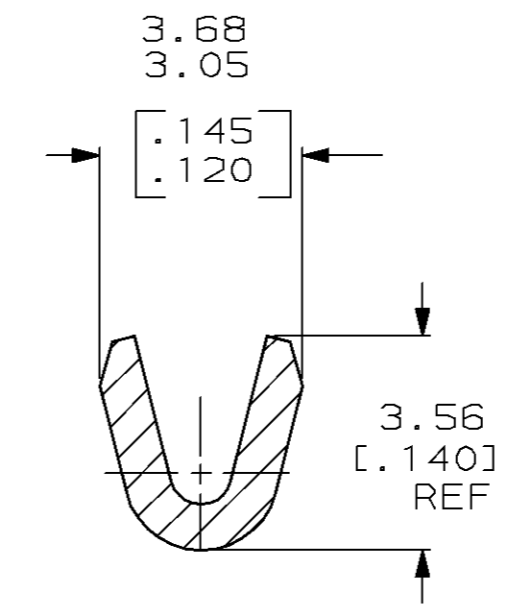
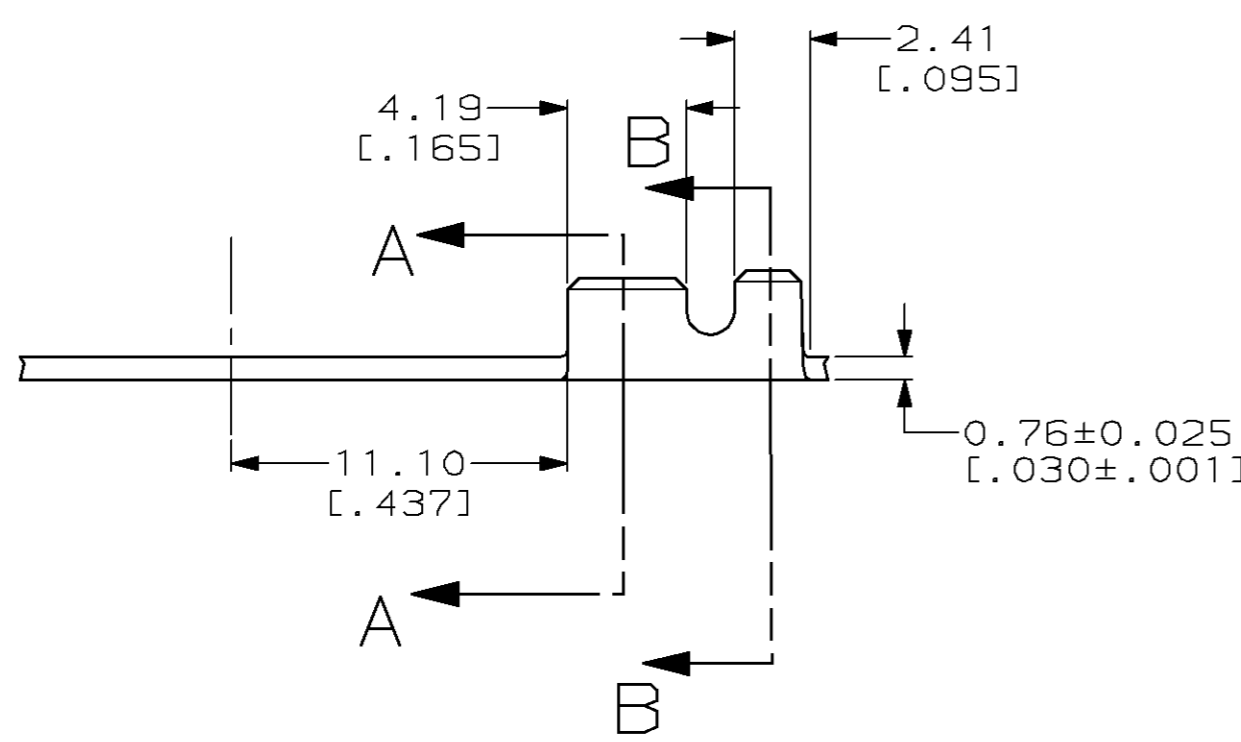
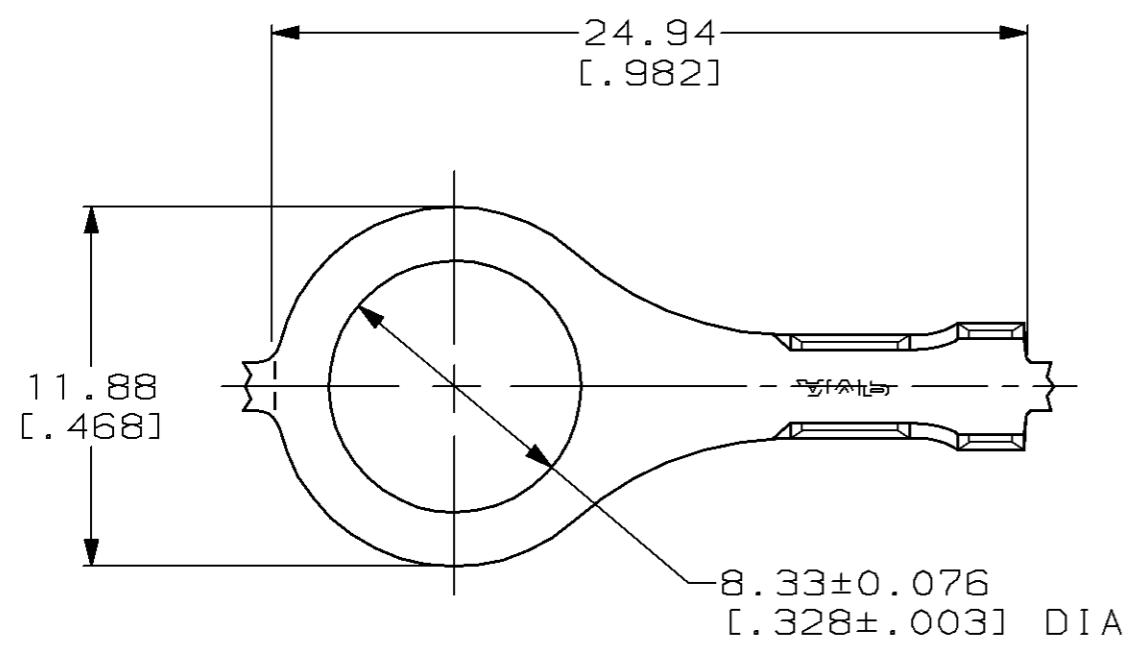

41013  
PART NO.

THIS DRAWING IS A CONTROLLED DOCUMENT.		DWN	JR RUTH	10/5/98	AMP Incorporated Harrisburg, PA 17105-3608		
DIMENSIONS: MM [INCHES]		CHK	MS FEHER	10/5/98			
TOLERANCES UNLESS OTHERWISE SPECIFIED:		APVD	J DUNCAN	10/5/98			
0 PLC ±- 1 PLC ±- 2 PLC ±0.38 [.015] 3 PLC ±- 4 PLC ±- ANGLES ±-		PRODUCT SPEC	-	-			
MATERIAL 082 BRASS		FINISH	0.002032 [.000080] MIN TIN	APPLICATION SPEC	-		
		WEIGHT	-	CUSTOMER DRAWING	SCALE 4:1		
		NAME		SIZE	CAGE CODE	DRAWING NO	RESTRICTED TO
		TERMINAL, RING		A3	00779	C= 41013	-
				SHEET	1	OF 1	REV H